

SPECIFICATION

Type: Pilot control valve, Working pressure: 16/25 bar.

Meet standards BS EN 1074-5, ISO 5208, BS EN 12266.1, BS EN 558-1.

Flanged to JIS 10/16K, BS4504 PN16/25, ANSI #150/300.

PRESSURE/TEMPERATURE RATINGS

Working pressure	16/25 bar
Testing Pressure	Shell: 24/37.5 bar
Working temperature	-10°C to 80°C
Suitable Media	

- The main valve will open against the system pressure differential whenever exceeds the pilot setting (adjustable).
- The main valve shall be a hydraulically operated, single diaphragm actuated. Y-pattern valves shall not be permitted. The valve shall contain a disc and diaphragm assembly that forms a sealed chamber below the valve cover, separating operating pressure from line pressure. The diaphragm shall be constructed of nylon reinforced (EPDM+ Nylon Fabric), and shall not seal directly against the valve seat and shall be fully supported by the valve body and cover. Rolling diaphragm construction will not be allowed and there shall be no pistons operating the main valve or any pilot controls.
- The main valve body and cover shall be Ductile iron GGG 500-7 and all internal cast components shall be Ductile Iron or (SUS 304) Stainless Steel. All Ductile Iron components, including the body and cover, shall be lined coated with an NSF 61 Certified Epoxy Coating applied by the electrostatic heat fusion process. All main valve throttling components (valve seat and disc guide) shall be Stainless Steel. The valve body and cover must be machined with a 360-degree locating lip to assure proper alignment.
- The disc and diaphragm assembly shall contain a Buna-N synthetic rubber (EPDM + Nylon Fabric) that is securely retained on sides by a disc retainer and disc guide. Diaphragm assemblies utilizing bolts or cap screws for component retention will not be permitted.
- The exposed portion of the EPDM + Nylon Fabric shall contact the valve seat and seal drip-tight. The disc and diaphragm assembly must be guided by two separate bearings, one installed in the valve cover and one concentrically located within the valve seat, to avoid deflection and assure positive disc-to-seat contact. Center guided valves will not be permitted. All necessary repairs shall be made from the top the valve while the body remains in line.
- Pilot control system for valve shall contain an external Y strainer, Differential relief pilot and ball valve on all body connect. All pilot control systems shall utilize Stainless steel tubing and fitting regardless of valve size.

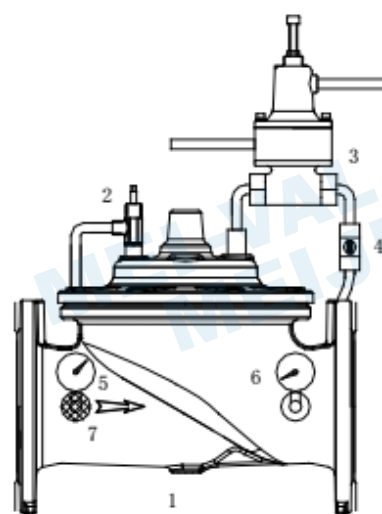

STANDARDS COMPONENTS

1. Main valve
2. Need valve
3. Differential Relief Control
4. Ball valve
5. Inlet Pressure gauges
6. Outlet Pressure gauges
7. Y- Strainer

FUNCTION:

- Throttles to main constant differential between two pressure points.
- Maintains preset pressure differential between high and low pressure zones.
- Opens on increase in differential pressure.
- Closes on decrease in differential pressure.
- Low pressure sense line field installed.
- Adjustable closes speed.
- Set-point is adjustable.
- High pressure sense line field installed.

Head Loss Curve

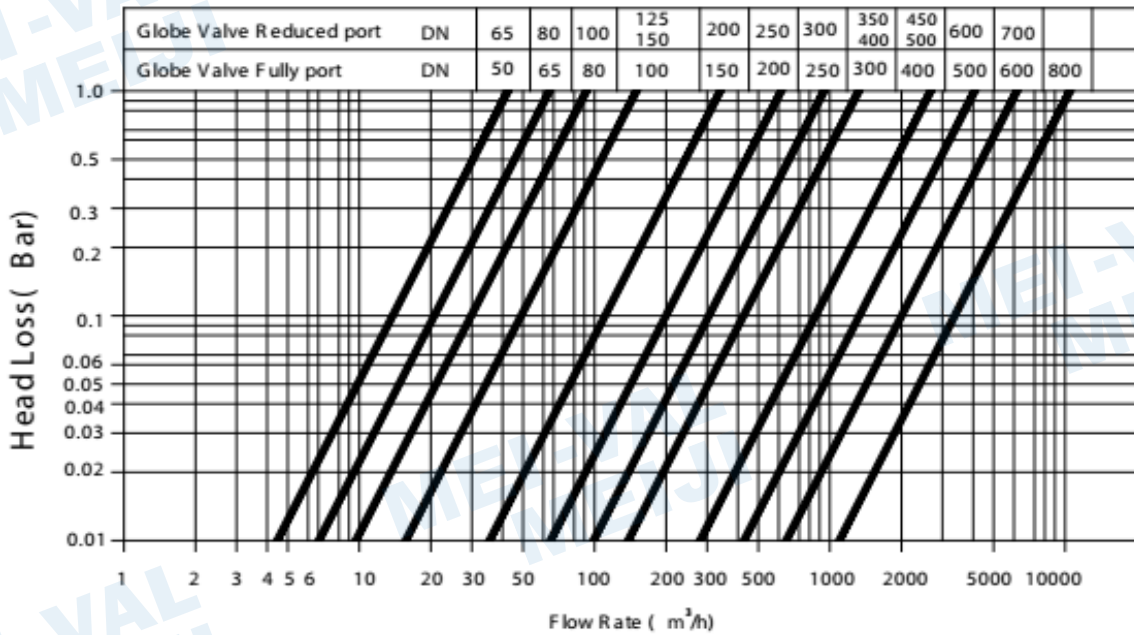

Cavitation

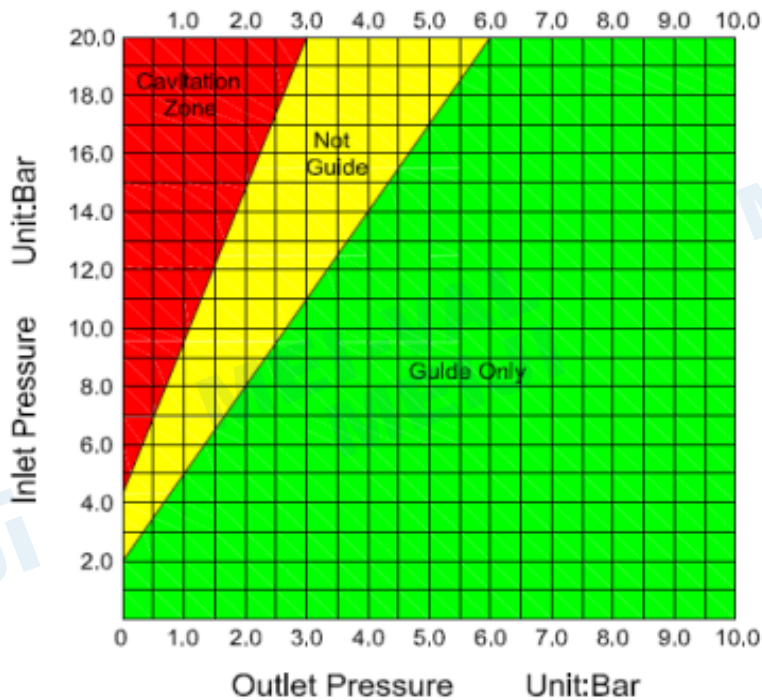

The main valve include: Main valve + Differential relief pilot control

Material & dimension of Main valve DN 50-350mm

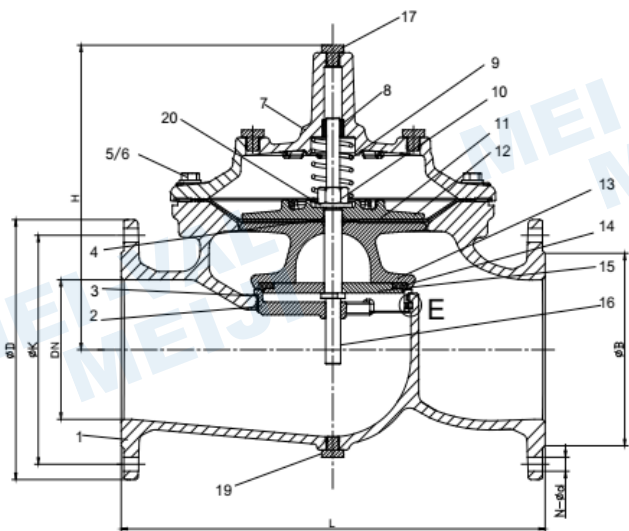

Parts List

No.	Description	Material	Standard
1	Body	Ductile Iron	GJS 500-7
2	Seat	Stainless Steel	AISI 304/316
3	O-ring	Rubber	NBR
4	O-ring	Rubber	NBR
5	Bolt	Stainless Steel	A2/A4
6	Washer	Stainless Steel	A2/A4
7	Bonnet	Ductile Iron	GJS 500-7
8	Bush	Bronze	C61900
9	Spring	Stainless Steel	AISI 304/316
10	Caulking Nut	Stainless Steel	A4
11	Diaphragm	Nylon Reinforced Rubber	EPDM +Nylon Fabric
12	Fixing holder	Ductile Iron	GJS 500-7
13	Disc Holder	Ductile Iron	GJS 500-7
14	Seal	Rubber	EPDM
15	Seat Retainer	Stainless Steel	AISI 304/316
16	Stem	Stainless Steel	AISI 304/316
17	Plug	Stainless Steel	AISI 304/316
18	Screw	Stainless Steel	A2/A4
19	Plug	Stainless Steel	A2/A4
20	Washer	Stainless Steel	A2/A4

Dimension

Unit :mm

DN	L	H	ϕD		ϕK		N- ϕD		N- ϕB	
			PN16	PN25	PN16	PN25	PN16	PN25	PN16	PN25
50	230	177	165	165	125	125	4- $\phi 19$	4- $\phi 19$	$\phi 99$	$\phi 99$
65	290	202	185	185	145	145	4- $\phi 19$	8- $\phi 19$	$\phi 118$	$\phi 118$
80	310	219	200	200	160	160	8- $\phi 19$	8- $\phi 19$	$\phi 132$	$\phi 132$
100	350	243	220	235	180	190	8- $\phi 19$	8- $\phi 23$	$\phi 156$	$\phi 156$
125	400	243	250	270	210	220	8- $\phi 19$	8- $\phi 28$	$\phi 156$	$\phi 156$
150	480	333	285	300	240	250	8- $\phi 23$	8- $\phi 28$	$\phi 211$	$\phi 211$
200	600	428	340	360	295	310	12- $\phi 23$	12- $\phi 28$	$\phi 266$	$\phi 274$
250	730	478	405	425	355	370	12- $\phi 28$	12- $\phi 31$	$\phi 319$	$\phi 330$
300	850	538	460	485	410	430	12- $\phi 28$	12- $\phi 31$	$\phi 370$	$\phi 389$
350	980	550	520	555	470	490	16- $\phi 28$	16- $\phi 34$	$\phi 429$	$\phi 448$

Material & dimension of Main valve DN 400-800mm

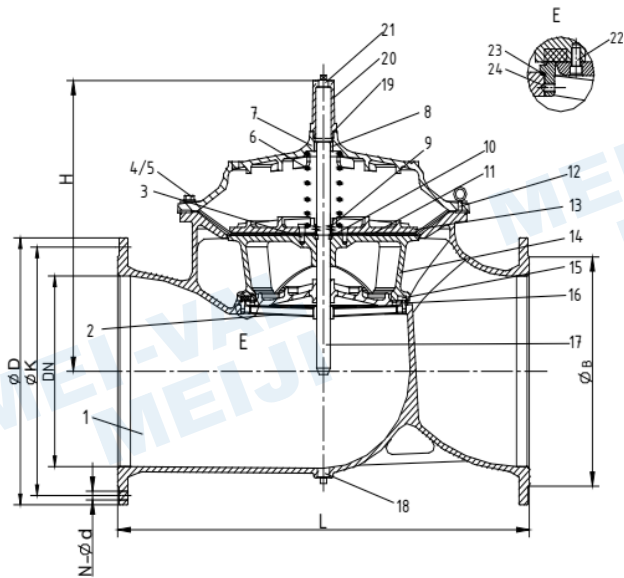

Parts List

No.	Description	Material	Standard
1	Body	Ductile Iron	GJS 500-7
2	Seat	Stainless Steel	AISI 304/316
3	Screw	Stainless Steel	A2/A4
4	Screw	Stainless Steel	A2/A4
5	Screw	Stainless Steel	A2/A4
6	Spring	Stainless Steel	AISI 304/316
7	Bonnet	Ductile Iron	GJS 500-7
8	Bush	Bronze	C61900
9	O-ring	Rubber	NBR
10	Fix Washer	Bronze	C61900
11	Diaphragm	Nylon Reinforced Rubber	EPDM +Nylon Fabric
12	Eye Bolts	Carbon Steel	1040
13	Fixing Holder	Ductile Iron	GJS 500-7
14	Disc Holder	Ductile Iron	GJS 500-7
15	Seal	Rubber	EPDM
16	Seal Retainer	Ductile Iron	GJS 500-7
17	Stem	Stainless Steel	AISI 304/316
18	Plug	Stainless Steel	AISI 304/316
19	O-ring	Rubber	NBR
20	Cap	Ductile Iron	GJS 500-7
21	Plug	Stainless Steel	AISI 304/316
22	Screw	Stainless Steel	A2/A4
23	O-ring	Rubber	NBR
24	Screw	Stainless Steel	A2/A4

Dimension

Unit :mm

DN	L	H	øD		øK		N-øD		N-øB	
			PN16	PN25	PN16	PN25	PN16	PN25	PN16	PN25
400	1100	670	580	620	525	550	16-ø31	16-ø37	480	503
450	1200	700	640	670	585	600	20-ø31	20-ø37	548	548
500	1250	790	715	730	650	660	20-ø34	20-ø37	610	609
600	1450	930	840	845	770	770	20-ø37	20-ø40	720	720
700	1650	950	910	960	840	875	24-ø37	24-ø43	720	720
800	1850	1260	1025	1085	950	990	24-ø40	24-ø49	900	928

Differential Relief Pilot

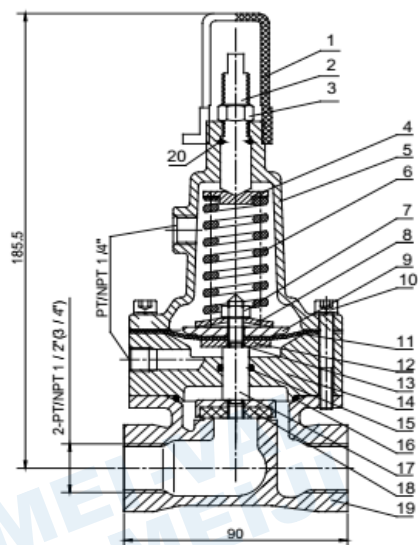

Part list & Material

No.	Description	Material	Standard
1	Cap	Plastic	ABS
2	Adjusting Screw	Stainless Steel	AISI 304
3	Jam Nut	Stainless Steel	AISI 304
4	Spring table	Stainless Steel	AISI 304
5	Bonnet	Stainless Steel	AISI 304
6	Spring	Spring Steel	SiCrV
7	Nut	Stainless Steel	A2
8	Spring table	Spring Steel	Mn-steel+Ni Plated
9	Fixing Holder	Stainless Steel	AISI 304
10	Screw	Stainless Steel	A2
11	Diaphragm	Nylon Reinforced Rubber	EPDM+Nylon
12	Gasket	Stainless Steel	AISI 304
13	O-Ring	Rubber	NBR
14	Internal Body	Stainless Steel	AISI 304
15	O-Ring	Rubber	NBR
16	O-Ring	Rubber	NBR
17	Stem	Stainless Steel	AISI 304
18	Disc	Stainless Steel+Rubber	AISI 304+EPDM
19	Body	Stainless Steel	AISI 304
20	O-Ring	Rubber	NBR

Installation + Assembly Directions

Installation.

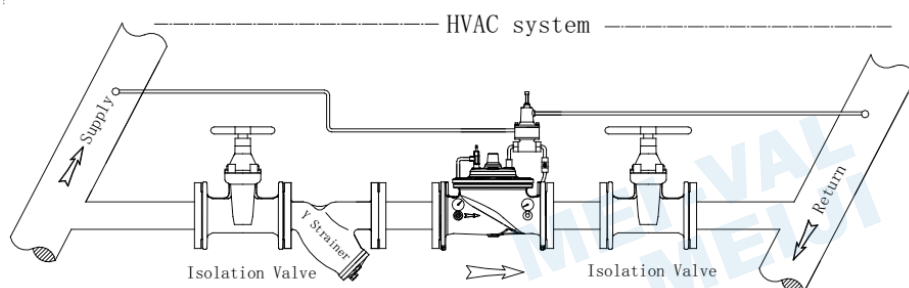

Assembly Directions

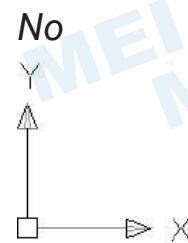

Yes

1. Connect the inlet to the main valve cover via tubing circuit.
2. Connect the outlet to the main valve outlet.
3. Connect the sensing chambers to: high pressure zone and low pressure zone.
4. Prior to installation, flush line to remove debris.
5. Install valve horizontally "in line" (cover facing up), so flow arrow matches flow through the line. Consult factory prior to ordering if installation is other than described.