

FIG.103, BRASS GATE VALVE, PN16

Size: DN 15 mm - 50 mm

SPECIFICATION

SCREWED-IN BONNET. SOLID WEDGE DISC.
NON-RISING STEM. INTEGRAL SEAT. ASBESTOS FREE.
THREADED TO BS 21, ISO-07, ASME B1.20.1



PRESSURE/TEMPERATURE RATING	
Working pressure	16 bar (WOG) Non Shock
Test pressure	Shell: 24 bar Hydrostatic Seat: 17 bar Hydrostatic 5.5 bar Air
Working temperature	-20°C ~ 120°C
Suitable Media	

MATERIAL LIST			
Part	Material	ASTM Spec.	BS Spec.
Body	Brass	B124 C37700	2874 CZ122
Bonnet	Brass	B124 C37700	2874 CZ122
Disc	Brass	B124 C37700	2874 CZ122
Stem	Brass Rod	B124 C36000	2874 CZ121
Packing	P.T.F.E		
Packing nut	Brass Rod	B16 C36000	2874 CZ121
Hand wheel	Cast Iron	A48 No.35	1452 Gr.250
Gland	Brass Rod	B124 C36000	2874 CZ121

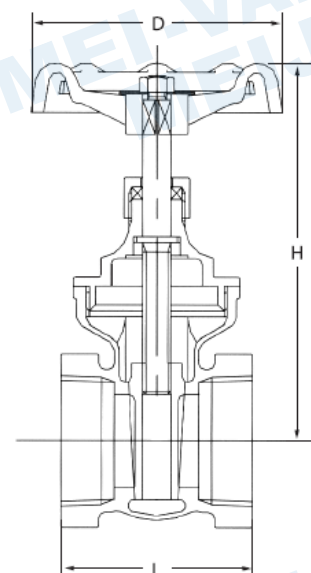

DIMENSIONS							
DN	mm	15	20	25	32	40	50
	Inch	1/2	3/4	1	1 1/2	1 1/4	2
L (mm)		53	57	62	72	73	87
H (mm)		72	77	87	108	117	138
D (mm)		53	53	59	59	71	78

Note:

1. If used for gas application, please consult our sales office.
2. Design and specifications are subject to change without prior notice.