

FIG. 107, BRONZE SWING CHECK VALVE, PN20

Size: DN 15 mm - 100 mm

SPECIFICATION

MSS SP - 80

SCREWED CAP. SWING TYPE DISC. INTEGRAL SEAT

THREADED TO BS 21, ISO-07, ASME B1.20.1

PRESSURE/TEMPERATURE RATING

Working pressure	20 bar (WOG) Non Shock
Testing pressure	Shell: 30 bar Hydrostatic Seat: 21 bar Hydrostatic 5.5 bar Air
Working temperature	-20°C to 120°C
Suitable Media	



MATERIAL LIST

Part	Material	ASTM Spec.	BS Spec.
Body	Bronze (Gunmetal)	B62 C83600	1400 LG2
Disc	Bronze (Gunmetal)	B62 C83600	1400 LG2
Cap	Bronze (Gunmetal)	B62 C83600	1400 LG2
Hinge pin	Brass Rod	B16 C38800	2874 CZ122
Gasket	Non-Asbestos.		

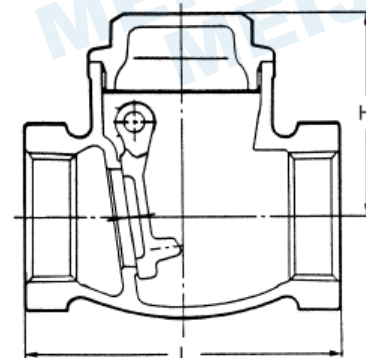

DIMENSIONS

DN	mm	15	20	25	32	40	50	65	80	100
	Inch	1/2	3/4	1	1 1/2	1 1/4	2	2 1/2	3	4
L (mm)		58	66	76	88	96	112	136	147	180
H (mm)		37	43	49	58	63	72	85	93	110

Note:

1. If used for gas application, please consult our sales office.
2. Design and specifications are subject to change without prior notice.