

SPECIFICATION

SCREWED CAP. SWING TYPE DISC. INTEGRAL SEAT
 THREADED TO BS 21, ISO-07, ASME B1.20.1

PRESSURE/TEMPERATURE RATING

Working pressure	16 bar (WOG) Non Shock
Testing pressure	Shell: 24 bar Hydrostatic Seat: 17 bar Hydrostatic 5.5 bar Air
Working temperature	-10°C to 110°C
Suitable Media	

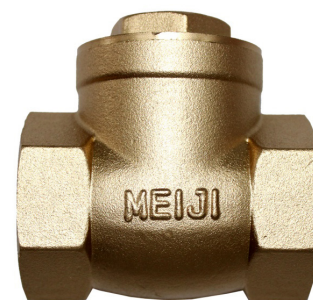

MATERIAL LIST

Part	Material	ASTM Spec.	BS Spec.
Body	Brass	B124 C37700	2874 CZ122
Bonnet	Brass	B124 C37700	2874 CZ122
Disc	Brass	B124 C37700	2874 CZ122
Hinge pin	Brass Rod	B124 C36000	2874 CZ121
Gasket	Non-Asbestos.		
Nut	Brass Rod	B16 C36000	2874 CZ121

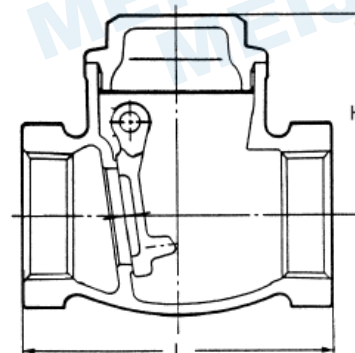

DIMENSIONS

DN	mm	15	20	25	32	40	50
	Inch	1/2	3/4	1	1 1/2	1 1/4	2
L (mm)		53	56	68	69	83	93
H (mm)		34	37	44	50	57	65

Note:

- If used for gas application, please consult our sales office.
- Design and specifications are subject to change without prior notice.