

FIG. 206, DIN 3352 F4 OS & Y, GATE VALVE, PN16

Size: DN 40 - 400 mm

SPECIFICATION

METAL SEATED, RISING STEM, OUTSIDE SCREW AND YOKE.
DIN 3352 (F4). FLANGED TO BS 4504 PN10/16, JIS10K, ANSI Class 125.

PRESSURE/TEMPERATURE RATINGS

| | |
|---------------------|-------------------------------|
| Working pressure | 16 bar |
| Testing Pressure | Shell: 24 bar, Seat: 17.6 bar |
| Working temperature | -10°C to 120°C |
| Suitable Media | |

MATERIALS

| Part | Material | EN Spec. |
|-------------------|-------------------------|----------------|
| Body | Ductile Iron | EN-JS1050 |
| Bonnet | Ductile Iron | EN-JS1050 |
| Disc | Ductile Iron | EN-JS1050 |
| Seat/Holding Ring | Brass | EN 12165 W603N |
| Stem/bolt/nut | Stainless steel | BS970 420S37 |
| O/Dust Ring | Graphite | Non-Asbestos |
| Hand-wheel | Cast Iron | EN-JL1040 |
| Painting | Red Epoxy Power Coating | |

DIMENSIONS

| Nominal | | | | Nominal | | | |
|---------|------|------|------|---------|------|------|------|
| Size mm | L mm | H mm | D mm | Size mm | L mm | H mm | D mm |
| 40 | 140 | 295 | 160 | 150 | 210 | 711 | 250 |
| 50 | 150 | 315 | 160 | 200 | 230 | 900 | 250 |
| 65 | 170 | 371 | 160 | 250 | 250 | 1093 | 320 |
| 80 | 180 | 424 | 200 | 300 | 270 | 1273 | 320 |
| 100 | 190 | 500 | 200 | 350 | 290 | 1500 | 400 |
| 125 | 200 | 598 | 200 | 400 | 310 | 1820 | 500 |

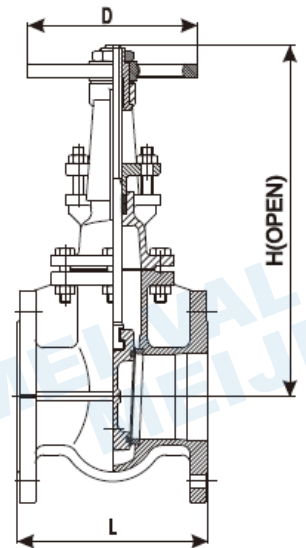
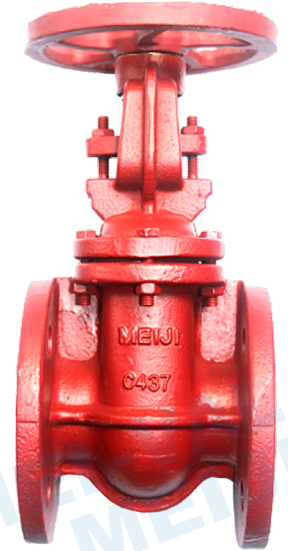

Note:

1. L: Face to face, H: Flange central to top.
2. JIS B2043 10K and other flange standards available upon request.
3. If used for gas application, please consult our sales office.
4. Design and specifications are subject to change without prior notice.